



# SL200

**Sliding Thermal Insulating System**  
Maximum space saving.



## System Identity

SL200 belongs to the generation of thermal insulation systems providing maximum space savings, high aesthetic, exceptional performance and excellent functionality.

The special design of the system is based on the architectural trend that incorporates straight untied lines thus satisfying a wide range of requirements, both in existing and in new buildings.

The series uses the anti bi-metal polyamide, the only solution (especially in sliding units) in order to prevent warping caused by the differences in temperature between the outside and inside profiles.

SL200 adds higher performance characteristics in its category, with thermal insulation  $U_f \geq 2.1 \text{ W/m}^2\text{K}$  and sound reduction up to 26 dB.

## Features & Benefits

- Triple rail solution of glass, mosquito screen and shutter in 98.5 mm width and 32 mm height.
- Fortified overlapping rails with mechanical corner connection for demanding constructions.
- Special designed central adaptor of excellent functionality for ultimate water and air tightness.
- Offers high thermal insulation by using additional profiles to the hook profile section.

## Configurations

### Sliding

2Leaf sliding, 3Leaf sliding, 4Leaf double sliding, 6Leaf double sliding, 2Leaf sliding with insect screen

### Combinations

2Leaf sliding SL200 with opening W450  
2Leaf sliding with insect screen SL200 with opening W450

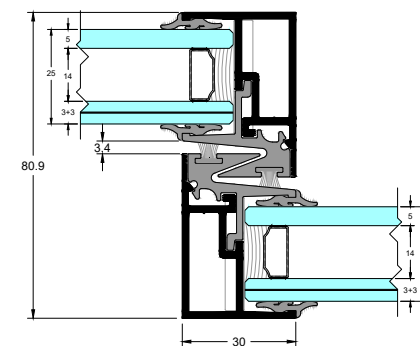
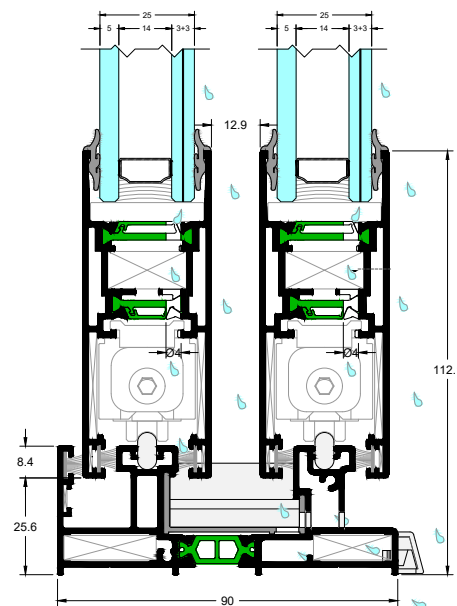

### HARDWARE

SLIDING	■
LIFT & SLIDE	

### INSULATION

ANTI-BI-METAL POLYAMIDES mm	18-30
-----------------------------	-------

### SYSTEM PROFILE DIMENSIONS

FRAME LIFT & SLIDE WIDTH mm	90
MIN. FRAME HEIGHT mm	32
MIN. FACE HEIGHT mm	80 / 86.5
INTERLOCKING PROFILE WIDTH mm	30
GLASS THICKNESS mm	up to 25

### CONSTRUCTION DIMENSIONS

SASH WIDTH mm	330-1800
SASH HEIGHT mm	510-2400
MAX. SASH DIMENSIONS mm (WxH)	1800x2200 / 1600x2400
MAX. SASH WEIGHT Kg	160

### CERTIFICATES/PERFORMANCES

AIR PERMEABILITY EN 12207	Class 3
WATER TIGHTNESS EN 12208	Class 3A
RESISTANCE TO WIND LOAD EN 12210	Class C3/B3
SOUND REDUCTION $R_w$ (C;Ctr) EN ISO 140-3	26 (0;-1) dB
THERMAL INSULATION $U_f$ EN ISO 10077-2	2.1-5.1 $\text{W/m}^2\text{K}$

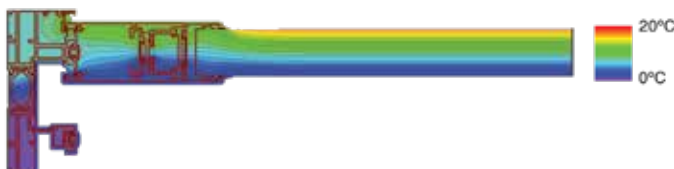

### Rate of Insulation

**$U_w = 2.11 \text{ W/m}^2\text{K}$**

Thermal conductivity coefficient has been calculated for the construction:  
1600x2200 with  $U_g = 1.1 \text{ W/m}^2\text{K}$   
Glass type: 5/14 (ARGON) / 3+3



FLAT